



# SY95

Hydraulic Excavator



## KEY FEATURES

- The independently developed control system with load sensing hydraulics use all available engine power to ensure maximum speed and power in all operating conditions
- Extra reinforcements in the boom, arm, swing platform and undercarriage increase stability and service life
- Efficient, powerful tier 4 final compliant engine

### Total Weight

9,180 Kg - 20,238 lb

### Rated Power

53.1 kW @ 2,100 rpm -  
72.1 hp @ 2,100 rpm

### Bucket Digging Force

63.6 kN - 14,298 lb

# SY95 Dimensions & Specifications

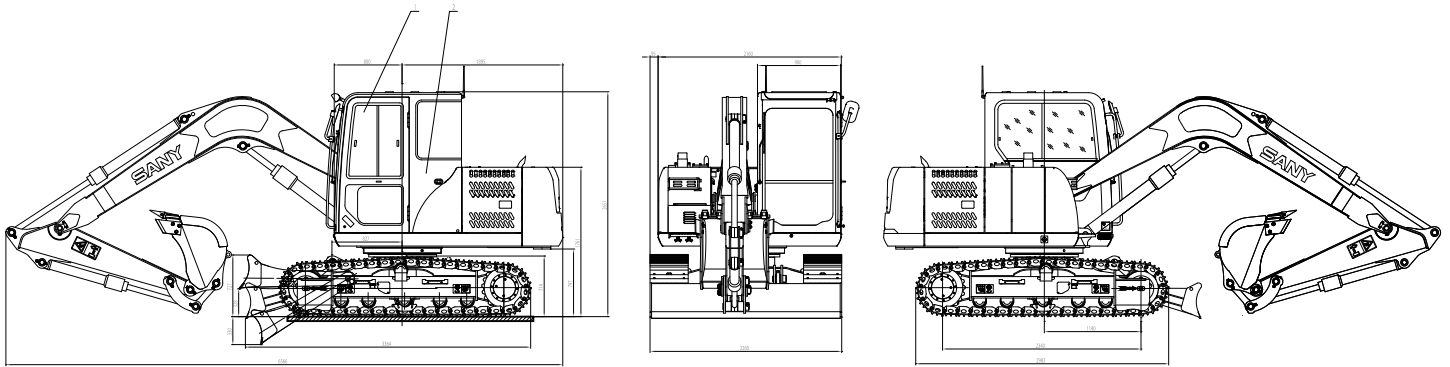

	Standard	Metric
Length (During Transportation)	21' 6"	6,560 mm
Width (Transportation/Operating)	7' 5"	2,260 mm
Height (During Transportation)	10' 6"	3,200 mm
Upper Structure Width	7' 1"	2,160 mm
Height of Dozer Blade	17"	420 mm
Standard Track Width	18"	450 mm
Track Gauge (Transportation/Operating)	5' 11"	1,810 mm
Min. Ground Clearance	13"	360 mm
Tail Swing Radius	6' 2"	1,885 mm
Track Length	9' 9"	2,980 mm
Track Height	2' 4"	714 mm

WORKING RANGE		
	Standard	Metric
Max. Digging Height	23' 10"	7,260 mm
Max. Dumping Height	17' 1"	5,210 mm
Max. Digging Depth	14' 2"	4,330 mm
Max. Vertical Digging Depth	10' 1"	3,080 mm
Min. Swing Radius	6' 6"	1,990 mm
Max. Height at Min. Swing Radius	18' 8"	5,700 mm
Dozer Blade Max. Height	13"	330 mm
Dozer Blade Max. Depth	13"	330 mm

MACHINE PARAMETERS		
	Standard	Metric
Machine Weight	20,238 lb	9,180 kg
Standard Bucket Capacity	0.51 yd <sup>3</sup>	0.39 m <sup>3</sup>
Rated Power	72.1 hp	53.1/2100 kW/rpm
Traveling Speed (Fast/Slow)	3.1/1.8 mph	5.0/2.9 km/h
Rotation Speed		11 rpm
Gradeability		70%/35°
Ground Pressure	5.6 psi	38.6 kPa
Engine Model		Yanmar
Maximum Torque	195 ft-lbs	295/1500 N-m/rpm
Displacement		3,318 L
Tractive Effort	18,547 lbf	83 kN
Bucket Digging Force	14,298 lbf	63.6 kN
Arm Digging Force	10,521 lbf	46.8 kN
Fuel Tank	42 gal	160 L
Hydraulic Tank	31.7 gal	120 L
Engine Oil	2.7 gal	10.2 L
Coolant System Capacity	3.2 gal	12 L
Final Drive	0.3 gal	2 x 1.2 L
Swing Drive	0.4 gal	1.5 L
Top Rollers		1
Bottom Rollers		5
Boom length	12' 10"	3.92 m
Arm Length	5' 7"	1.7 m
Optional Bucket (m <sup>3</sup> )		0.2-0.4 m <sup>3</sup>